



LED Drivers for
UL Class 1 Fixed



LED Drivers for
UL Class 1 Dimming



LED Drivers for
UL Class 1 Programmable



LED Drivers for
UL Class 2 Fixed



LED Drivers for
UL Class 2 Dimming



LED Drivers for UL Class 1 & 2
Downlighting and Tracklighting

Xitanium LED ELECTRONIC DRIVERS

Contents

Philips Xitanium Programmable LED Drivers _____	6-2 to 6-4
General Information _____	6-5
Xitanium LED Driver Specifications _____	6-6 to 6-9
Xitanium LED Driver Dimensions _____	6-10
Xitanium LED Driver Wiring Diagrams _____	6-11 to 6-12

Corporate Offices
(800) 322-2086

Customer Support/Technical Service
(800) 372-3331 • (+) | 847 390-5000 (International)

Visit our web site at www.philips.com/advance

Xitanium LED ELECTRONIC DRIVERS

Philips Xitanium Programmable LED Drivers

Ultimate flexibility for LED lighting manufacturers

Optimized to meet the ever-evolving needs of today's LED lighting manufacturers, Xitanium Programmable LED Drivers are a one-stop solution for the varying power needs of industrial high bay, highway, urban street, as well as area and flood lighting applications. Offering an unparalleled level of flexibility, these drivers provide a large number of features which can be customized based on the desired functionality of the luminaire design with a simple programming* interface. With multiple choices for current output levels, module temperature control settings and a network-ready DALI interface, this is an easily integrated driver solution. Luminaire designers and manufacturers are also able to streamline logistics without compromising on performance.

Benefits include:

- Robust programmable solution that offers ultimate design flexibility with a reliable long lifetime
- Reduced SKU complexity and simplified logistics management (one driver to serve many needs)
- Multiple dimming options provide energy savings and can reduce light pollution and CO₂ impact
- Easily programmable user interface for onsite customization of driver requirements
- Optimized life expectancies of up to 100,000 hours**
- Driver programmability provides hours for the ever-evolving improvements in LED efficacy, removing the need to design-in a new LED driver as technology improves or changes



* Programming the driver requires an interface device between your computer and the DALI connection on the driver. Please contact your Philips sales representative for the programming interface.

** Minimum 90% survivals based on MTBF modeling.

Xitanium LED ELECTRONIC DRIVERS

Feature highlights

- Robust protection against moisture and vibration
- Programmable Adjustable Output Current (AOC):
The power to choose the LED current that is optimal for the LED PCB
- Module Temperature Control Protection (MTC):
Set the limit temperature level at which the driver starts to dim the LEDs
- Constant Light Output (CLO): Regulates required light output over life to maximize efficiency
- Over the Life (OTL): Driver provides an end of life signal for easy maintenance
- Integrated Dynadimmer, classic and time based, DALI or 1-10V dimming protocols (Dynadimmer override is also available)
- Lighting system diagnostic (beta version)

Rugged design

Xitanium Programmable LED drivers are designed for both indoor and outdoor specification to foster reliability and long life. Exceptionally robust construction provides protection against dust, moisture and destructive vibrations, and full functionality across a wide temperature spectrum. The drivers are designed to deliver maximum lifetime of 100,000 hours.*

Reliability

Helping to improve the reliability of an LED luminaire, the Module Temperature Control (MTC) feature manages excessive temperatures of the PCB board. High heat negatively impacts the useful life of the module, and can increase maintenance costs. The driver reads the temperature of the LED module, and once it exceeds the specified threshold, will automatically reduce the current to the LEDs, dimming the lights and cooling down the module. Even the most robust LED solutions eventually approach end of useful life. The luminaire manufacturer can program the Over the Life (OTL) indicator function to signal that the LED module should be replaced.

* Minimum 90% survivals based on MTBF modeling.

Minimizing power consumption over life

All lighting sources suffer from a depreciation of light output over time. To ensure the minimum required light levels at lamp's end of life, most systems consume more power than necessary. The Constant Light Output (CLO) functionality enables the LEDs to always deliver the required light output by gradually increasing the current over the lifetime of the module, compensating for the reduction in light.

Benefits of dimming

The remarkable energy savings and CO₂ reductions achieved with LED lighting solutions can be further extended with dimming. Lowering the light levels during off-peak hours also minimizes light pollution. Xitanium Programmable LED drivers offer a full range of dimming options, with both stand-alone and network protocols. The integrated Dynadimmer functionality offers multiple dimming profiles. The 1-10V interface allows for simplified, one way management, while the DALI interface makes any installation with the Xitanium Programmable LED driver ready for a fully networked control system.

Applications

- Highways
- Urban streets
- Area and flood lighting
- High bay, industrial

Xitanium LED ELECTRONIC DRIVERS

Product specifications

Output current range (mA)	Output voltage range (V)	Output power (W)	Dimming range (%)	Efficiency range (at max. load)	Input voltage range (Vac)	Inrush current peak (A)	Inrush current width to 50% (τ_s)	Power factor (100% load)	Power factor (dimmed 50%)	Lifetime* @ Tcase life 71° C (10% failure)
Xitanium 75W										
350-700	80-152	30-75	100-10	$\geq 92\%$	120-277	108	140	≥ 0.97	≥ 0.92	100,000
Xitanium 150W										
350-700	125-280	30-150	100-10	$\geq 93\%$	120-277	108	140	≥ 0.97	≥ 0.94	100,000

* Minimum 90% survivals based on MTBF modeling.

General product characteristics

Rated frequency:	50/60 Hz
T ambient:	-40 to +55° C
T max:	+80° C
THD:	20%

External RSET

Factory default setting enables customization of the output current without the programming interface, offering choices in a continuous range between 350 and 700 mA. The current value is determined by placing a specific resistor between the Rset (yellow) and Common (ble/wht) wires (RSET) and Signal ground (COMN) wires. Please refer to the Design-in Guide for full range of values.

Programming note

Xitanium Programmable LED drivers are shipped from factory with the following default settings:

Adjustable output current (AOC) Use external RSET. If no resistor connected, driver will deliver 700mA)

Module thermal protection (MTC) Enabled (NTC2-15 k+390 Ohm)

Adjustable startup time 1000 ms

Over the life (OTL) indicator Disabled

Dimming interface selection 1-10 V (minimum dim level 10%)

Constant light output (CLO) Disabled

For complete details, please refer to the Design-in Guide.

Dimensions

Xitanium 75W & 150W Programmable LED drivers	F1	F2	F3	F4	F5	F6
inches	8.31"	1.48"	2.33"	8.84"	9.47"	5.2"
mm	211.14	37.61	59.13	224.63	240.51	130

LED Drivers
Xitanium

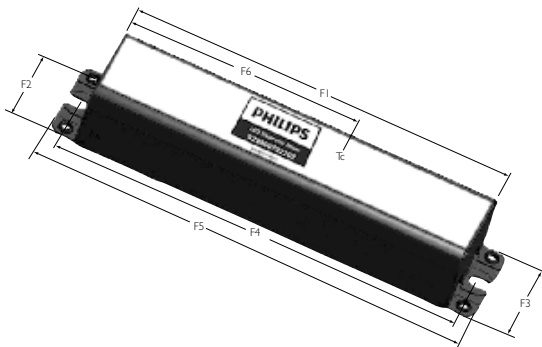
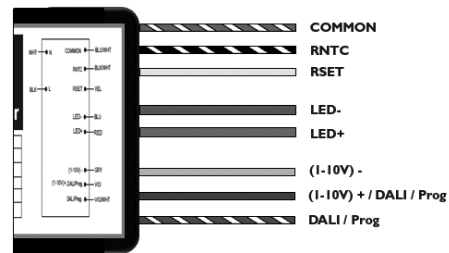
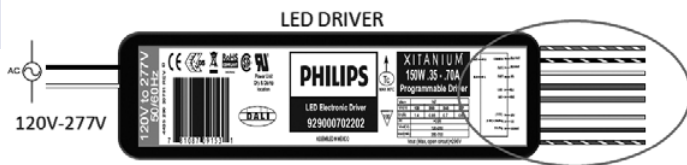



Catalog Number Explanation

LED	INT	A	C035	V425	D	N	M																																							
<p>Packaging: M = Midpack I = Individual Pack B = Bulk Pack</p> <p>Fixed or Dimming: FO = Fixed DL= Dimming (0-10V) NON-Isolated in F-can DO= Dimming (0-10V) Isolated F3= Tritap DN= Dimming (0-10V) NON-Isolated FL= Fixed in F-can</p> <p>Max Current or Max Voltage:</p> <table border="1"> <tr> <td>210=210V</td> <td>80=80V</td> <td>24=24V</td> <td>18=1.8A</td> <td>50=5.0A</td> <td>24=24V</td> </tr> <tr> <td>425=425V</td> <td>33=3.3A</td> <td>07=0.7A</td> <td>20=2.0A</td> <td>30=3.0A</td> <td>60=60V</td> </tr> <tr> <td>140=140V</td> <td>28=2.8A</td> <td>21=2.1A</td> <td>22=2.2A</td> <td>32=3.2A</td> <td>80=80V</td> </tr> <tr> <td>280=280V</td> <td>10=1.0A</td> <td>14=1.4A</td> <td>36=36V</td> <td>41=4.1A</td> <td></td> </tr> </table> <p>Constant Current or Constant Voltage: C= Constant Current V= Constant Voltage</p> <p>Max Current or Max Voltage:</p> <table border="1"> <tr> <td>0350=350mA</td> <td>0700=700mA</td> <td>0024=24V</td> <td>700=700mA</td> <td>1600=1.6A</td> </tr> <tr> <td>0400=400mA</td> <td>1050=1.05A</td> <td>0012=12V</td> <td>0520=520mA</td> <td>1000=1.0A</td> </tr> <tr> <td>0530=530mA</td> <td>2000=2.0A</td> <td>0036=36V</td> <td>1400=1.4A</td> <td></td> </tr> </table> <p>Input Voltage: A=AC Voltage D=DC Voltage</p> <p>Input Voltage: INT= 120 - 277V (UL, CSA) UNI = 120 - 240V 120 = 120V (UL, CSA) HCN = 347-480V (UL, CSA) 277 = 277V (UL, CSA)</p>								210=210V	80=80V	24=24V	18=1.8A	50=5.0A	24=24V	425=425V	33=3.3A	07=0.7A	20=2.0A	30=3.0A	60=60V	140=140V	28=2.8A	21=2.1A	22=2.2A	32=3.2A	80=80V	280=280V	10=1.0A	14=1.4A	36=36V	41=4.1A		0350=350mA	0700=700mA	0024=24V	700=700mA	1600=1.6A	0400=400mA	1050=1.05A	0012=12V	0520=520mA	1000=1.0A	0530=530mA	2000=2.0A	0036=36V	1400=1.4A	
210=210V	80=80V	24=24V	18=1.8A	50=5.0A	24=24V																																									
425=425V	33=3.3A	07=0.7A	20=2.0A	30=3.0A	60=60V																																									
140=140V	28=2.8A	21=2.1A	22=2.2A	32=3.2A	80=80V																																									
280=280V	10=1.0A	14=1.4A	36=36V	41=4.1A																																										
0350=350mA	0700=700mA	0024=24V	700=700mA	1600=1.6A																																										
0400=400mA	1050=1.05A	0012=12V	0520=520mA	1000=1.0A																																										
0530=530mA	2000=2.0A	0036=36V	1400=1.4A																																											
<p>General LED= Xtanium LED Driver</p>																																														





Xitanium LED Electronic Drivers

Max Output Power (W)	Output Voltage (V)	Output Current (Amps)	Min/Max Ambient Temp (C/F)	Input Volts	Catalog #	Certifications		Input Current Max (A)	Input Power Max (W)	Max. THD %	Power Factor	Env. Rating	Dim./Wiring Dia.	
UL Class I Fixed Drivers														
100	60 ~ 140	0.350	-40C / 55C	120	LEDINTA700C140F30	✓	✓	0.53	64	20	0.99	Dry, Damp	F/5	
				230				0.29	67					
				277				0.25	69					
		0.525		120				0.78	94					
				230				0.41	94					
				277				0.35	97					
				0.700				120	1.04					125
								230	0.55					127
								277	0.46					127
115	120 ~ 280	0.400	-40C / 55C	120 277	LEDINTA0400C280FO	✓	✓	1.07	128	20	0.90	Dry, Damp	F/2	
115	120 ~ 280	0.400	-40C / 55C	347 480	LEDHCNA0400C280FO	✓	✓	0.37	128	20	0.90	Dry, Damp	F/11	
150	120 ~ 425	0.350	-40C / 55C	120	LEDINTA0350C425FO	✓	✓	1.40	165	20	0.90	Dry, Damp	F/1	
				277				0.60						
150	60 ~ 210	0.700	-40C / 55C	120	LEDINTA0700C210FO	✓	✓	1.40	165	20	0.99	Dry, Damp	F/1	
				250				0.67						
				277				0.60						
150	120 ~ 425	0.350	-40C / 55C	347	LEDHCN0350C425FO	✓	✓	0.50	165	20	0.99	Dry, Damp	F/11	
				480				0.35						
150	60 ~ 210	0.700	-40C / 55C	347	LEDHCN0700C210FO	✓	✓	0.50	165	20	0.99	Dry, Damp	F/11	
				480				0.35						
150	60 ~ 210	0.700	-40C / 55C	120	LEDINTA700C210A54	✓	✓	1.40	165	20	0.90	Dry, Damp	F/1	
				277										
UL Class I Dimming Drivers														
40	40 ~ 77	0.35~0.52	-40C / 55C	120 277	LEDINTA0520C80DB	✓	✓	0.36	47	20	0.90	Dry, Damp	H/	
150	120 ~ 425	0.35	-40C / 55C	120	LEDINTA0350C425DO	✓	✓	1.40	165	20	0.90	Dry, Damp	F/2	
				277				0.60						
150	120 ~ 180	0.53	-40C / 55C	120	LEDINTA0530C280DO	✓	✓	1.40	165	20	0.90	Dry, Damp	F/2	
				277				0.60						
150	60 ~ 210	0.7	-40C / 55C	120	LEDINTA0700C210DO	✓	✓	1.40	165	20	0.90	Dry, Damp	F/2	
				277				0.60						
				250Vdc				0.67						
150	40 ~ 140	1.05	-40C / 55C	120	LEDINTA1050C140DO	✓	✓	1.37	165	20	0.90	Dry, Damp	F/2	
				240				0.71						
				277				0.59						
150	120 ~ 425	0.35	-40C / 55C	347	LEDHCNA0350C425DN	✓	✓	0.50	165	20	0.90	Dry, Damp	F/2	
				480				0.35						
150	120 ~ 180	0.53	-40C / 55C	347	LEDHCNA0530C280DN	✓	✓	0.50	165	20	0.90	Dry, Damp	F/2	
				480				0.35						
150	60 ~ 210	0.7	-40C / 55C	347	LEDHCNA0700C210DN	✓	✓	0.50	165	20	0.90	Dry, Damp	F/10	
				480				0.35						

LED Drivers
Xitanium



Xtanium LED Electronic Drivers

Max Output Power (W)	Output Voltage (V)	Output Current (Amps)	Min/Max Ambient Temp (C/F)	Input Volts	Catalog #	Certifications		Input Current Max (A)	Input Power Max (W)	Max. THD %	Power Factor	Env. Rating	Dim./ Wiring Dia.
													
UL Class I Programmable Drivers													
75	80 ~ 152	0.350 ~0.70	-40C / 55C	120	929000702302M	✓	✓	0.70	85	20	0.95	Dry, Damp	F/12
				200				0.45					
				240				0.35					
				277				0.30					
75	80 ~ 152	0.350 ~0.70	-40C / 55C	120	929000704913M	✓	✓	0.70	85	20	0.95	Dry, Damp	F/12
				200				0.45					
				240				0.35					
				277				0.30					
150	125 ~ 280	0.350 ~0.70	-40C / 55C	120	929000702202M	✓	✓	1.40	165	20	0.95	Dry, Damp	F/12
				200				0.85					
				240				0.70					
				277				0.60					
150	125 ~ 280	0.350 ~0.70	-40C / 55C	120	929000705113M	✓	✓	1.40	165	20	0.95	Dry, Damp	F/12
				200				0.85					
				240				0.70					
				277				0.60					



Xtanium LED Electronic Drivers

Max Output Power (W)	Output Voltage (V)	Output Current (Amps)	Min/Max Ambient Temp (C/F)	Input Volts	Catalog #	Certifications		Input Current Max (A)	Input Power Max (W)	Max. THD %	Power Factor	Env. Rating	Dim./ Wiring Dia.
						SP	UL						
UL Class 2 Fixed Drivers													
3.5	12	0.350	-10C / 40C	120	LEDUNIA0350C12F		✓	0.06	7	20	0.9	Dry	G/3
				230									
8	2.8 ~ 12	0.700	-10C / 40C	120	LEDUNIA0350C12F		✓	0.25	15	20	0.9	Dry	G/3
				230									
12	2.8 ~ 33	0.350	-40C / 55C	120	LEDI20A0350C33F	✓	✓	0.13	15	20	0.9	Dry	A/6
12	2.8 ~ 28	0.350	-40C / 55C	120	LEDI20A0350C28FO	✓	✓	0.10	12.5	20	0.9	Dry, Damp	C/1
12	2.8 ~ 12	1.000	-40C / 55C	120	LEDI20A0012V10F	✓	✓	0.13	15	20	0.9	Dry, Damp	C/1
17	2.8 ~ 24	0.700	-40C / 55C	120	LEDI20A0700C24F	✓	✓	0.18	21.5	20	0.9	Dry	A/6
17	2.8 ~ 24	0.700	-40C / 55C	120	LEDI20A0700C24FO	✓	✓	0.18	21.5	20	0.9	Dry, Damp	C/1
17	24	0.700	-40C / 55C	120	LEDI20A0024V07F	✓	✓	0.18	21.5	20	0.9	Dry, Damp	A/6
20	2.8 ~ 28	0.700	-40C / 55C	120	LEDI20A0700C28FO	✓	✓	0.20	24	20	0.9	Dry, Damp	C/1
20	10 ~ 28	0.700	-40C / 55C	277	LED277A0700C28FO	✓	✓	0.09	24	20	0.9	Dry, Damp	C/1
25	18 ~ 36	0.3~0.7	-20C / 55C	120	929000601003	✓	✓	0.20	30	20	0.9	Dry, Damp	B/8
				277									
25	2.8 ~ 12	2.100	-40C / 60C	120	LEDI20A0012V21F	✓	✓	0.25	30.5	20	0.9	Dry	B/8
25	2.8 ~ 24	1.050	-40C / 60C	120	LEDI20A0024V10F	✓	✓	0.26	30.9	20	0.9	Dry	B/8
34	2.8 ~ 24	1.400	-40C / 60C	120	LEDI20A1400C24F	✓	✓	0.35	42	20	0.9	Dry	B/8
34	2.8 ~ 24	1.400	-40C / 60C	120	LEDI20A0024V14FO	✓	✓	0.35	42	20	0.9	Dry, Damp	E/7
40	2.8 ~ 24	1.750	-40C / 60C	120	LEDI20A0024V18FO	✓	✓	0.42	50	20	0.9	Dry	B/8
40	2.8 ~ 24	1.750	-40C / 60C	120	LEDI20A0024V18FO	✓	✓	0.42	50	20	0.9	Dry, Damp	E/7
48	24	0.10 ~ 2.000	-40C / 55C	120	LEDINTA0024V20FLO	✓	✓	0.48	57	20	0.9	Dry, Damp	F/1
				277		✓	✓	0.22					
53	24	2.200	-40C / 55C	120	LEDINTA0024V22FO	✓	✓	0.50	62	20	0.90	Dry, Damp	D/1
				277		✓	✓	0.25					
58	9 ~ 36	1.600	-40C / 55C	120	LEDINTA1600C36FO	✓	✓	0.55	68	20	0.90	Dry, Damp	D/1
				277		✓	✓	0.25					
10 ~ 60	12	0.8 ~ 5.000	-40C / 55C	120	LEDI20A0012V50F	✓	✓	0.63	75	20	0.90	Dry, Damp	D/1
				277	✓	✓							
60	12	0.10 ~ 5.000	-40C / 55C	120	LEDI20A0012V50FO	✓	✓	0.60	70	20	0.99	Dry, Damp	D/1
				277		✓	✓						
67	24	0.10 ~ 2.800	-40C / 55C	120	LEDINTA0024V28FO	✓	✓	0.65	78	20	0.99	Dry, Damp	D/1
				277		✓	✓	0.28					
72	24	31.10 ~ 3.000	-40C / 55C	120	LEDINTA0024V30FLO	✓	✓	0.72	86	20	0.90	Dry, Damp	F/1
				277		✓	✓	0.32					
77	24	3.200	-40C / 55C	120	LEDINTA0024V32FO	✓	✓	0.75	91	20	0.90	Dry, Damp	D/1
				277		✓	✓	0.35					
10 ~ 80	24	0.8 ~ 3.300	-40C / 55C	120	LEDI20A0024V33F	✓	✓	0.79	95	20	0.99	Dry, Damp	D/1
100	3.5 ~ 24	0.10 ~ 4.160	-40C / 55C	120	LEDINTA0024V41FLO	✓	✓	0.95	117	20	0.90	Dry, Damp	F/1
				277		✓	✓	0.42					
100	3.5 ~ 24	0.10 ~ 4.160	-40C / 55C	120	LEDINTA0024V41FO	✓	✓	0.95	117	20	0.90	Dry, Damp	F/1
				277		✓	✓	0.40					
100	3.5 ~ 24	0.10 ~ 4.160	-40C / 55C	347	LEDHCNA0024V41FLO	✓	✓	0.32	117	20	0.90	Dry, Damp	F/1
				480		✓	✓	0.23					
DC/DC Dimming Controller													
60	12	5.000	-40C / 55C	12Vdc	913710830902	✓	✓	5.00	60	20	0.90	Dry, Damp	C/4
100	24	4.100		24Vdc				4.10	100				

LED Drivers
Xtanium



Xtanium LED Electronic Drivers

Max Output Power (W)	Output Voltage (V)	Output Current (Amps)	Min/Max Ambient Temp (C/F)	Input Volts	Catalog #	Certifications		Input Current Max (A)	Input Power Max (W)	Max. THD %	Power Factor	Env. Rating	Dim./ Wiring Dia.
						SP	UL						
UL Class 2 Dimming Drivers													
20	10.0 ~ 28.0	0.7	-20C / 55C	120	LEDI20A0700C28DO	✓	✓	0.2	24	20	0.90	Dry, Damp	C/2
25	24.0	0.6 ~ 1.05	-20C / 55C	120	LEDI20A0024V10D		✓	0.25	30	20	0.90	Dry, Damp	B/9
48	24.0	1.0 ~ 2.0	-20C / 55C	120	LEDINTA2000C24DO	✓	✓	0.5	59	15	0.90	Dry, Damp	I/15
				230				0.25					
				277				0.2					
48	24.0	0.10 ~ 2.0	-40C / 55C	120	LEDINTA0024V20DLO	✓	✓	0.48	57	20	0.90	Dry, Damp	F/2
				277				0.22					
72	24.0	0.10 ~ 3.0	-40C / 55C	120	LEDINTA0024V30DLO	✓	✓	0.72	86	20	0.90	Dry, Damp	F/2
				277				0.322					
100	24.0	0.10 ~ 4.16	-40C / 55C	120	LEDINTA0024V41DLO	✓	✓	0.95	117	20	0.90	Dry, Damp	F/2
				277				0.40					
UL Class 1 and Class 2 Dimming Drivers for downlighting and tracklighting													
30	25 ~ 56	350 ~ 520	-20C / 55C	120	LEDINTA0520C60DB	✓	✓	0.30	36	20	0.90	Dry, Damp	H/14
				277									
39	20 ~ 56	200 ~ 700	-40C / 55C	120	913701213402	✓	✓	0.34	44	20	0.90	Dry, Damp	H/13
				277									
40	40 ~ 77	350 ~ 520	-20C / 55C	120	LEDINTA0520C80DB	✓	✓	0.36	47	20	0.90	Dry, Damp	H/14
				277									
50	25 ~ 48	700 ~ 1050	-40C / 55C	120	LEDINTA1000C60DB	✓	✓	0.50	59	20	0.90	Dry, Damp	H/14
				277									
UL Class 1 and Class 2 Indoor Programmable Drivers for downlighting and tracklighting													
50	27 ~ 54	0.300 ~ 1.000	-20C / 50C	277	XV050C100V054DPM1M	✓	✓	0.205	57	20	0.90	Dry, Damp	H/14
60	50 ~ 80	0.300 ~ 1.000	-20C / 50C	277	XV060C100V080DPM1M	✓	✓	0.246	68	20	0.90	Dry, Damp	H/14
25	18 ~ 36	0.300 ~ 1.000	-20C / 50C	277	XV025C100V036DPM1M	✓	✓	0.103	28	20	0.90	Dry, Damp	H/14
25	27 ~ 54	0.200 ~ 0.500	-20C / 50C	277	XV025C050V054DPM1M	✓	✓	0.103	28	20	0.90	Dry, Damp	H/14
50	27 ~ 54	0.300 ~ 1.000	-20C / 50C	120	XR050C100V054XPM1M	✓	✓	0.473	57	20	0.90	Dry, Damp	H/14
60	50 ~ 80	0.300 ~ 1.000	-20C / 50C	120	XR060C100V080XPM1M	✓	✓	0.568	68	20	0.90	Dry, Damp	H/14
25	18 ~ 36	0.300 ~ 1.000	-20C / 50C	120	XR025C100V036XPM1M	✓	✓	0.237	28	20	0.90	Dry, Damp	H/14
25	27 ~ 54	0.200 ~ 0.500	-20C / 50C	120	XR025C050V054XPM1M	✓	✓	0.237	28	20	0.90	Dry, Damp	H/14
25	18 ~ 36	0.300 ~ 1.000	-20C / 50C	120	XR025C100V036LPM1M	✓	✓	0.237	28	20	0.90	Dry, Damp	H/14
25	18 ~ 36	0.300 ~ 1.000	-20C / 50C	120	XI025C100V036XPL1M	✓	✓	0.237	28	20	0.90	Dry, Damp	H/14
				277				0.101					
50	27 ~ 54	0.300 ~ 1.000	-20C / 50C	120	XI050C100V054XPL1M	✓	✓	0.473	57	20	0.90	Dry, Damp	H/14
				277				0.203					
75	27 ~ 54	0.700 ~ 2.000	-20C / 50C	120	XI075C200V054YPT1M	✓	✓	0.710	85	20	0.90	Dry, Damp	I/14
				277				0.304					
75	27 ~ 54	0.700 ~ 2.000	-20C / 50C	120	XI075C200V054XPT1M	✓	✓	0.710	85	20	0.90	Dry, Damp	I/14
				277				0.304					

Xtanium LED ELECTRONIC DRIVERS

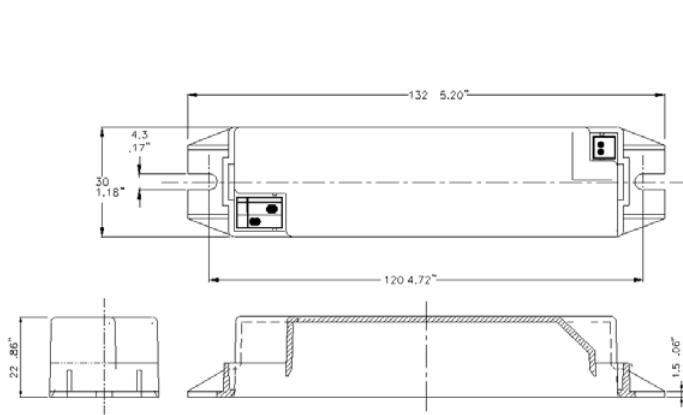

Fig. A

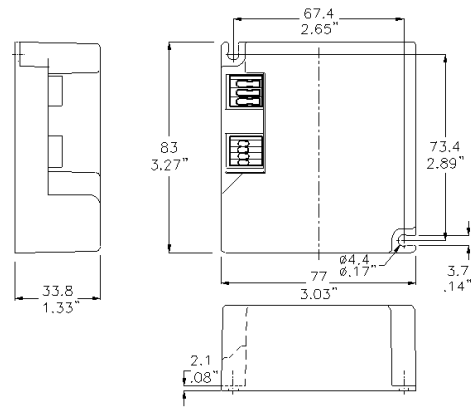

Fig. B

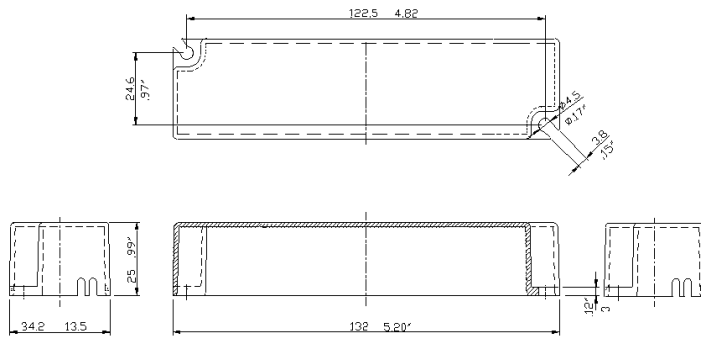

Fig. C

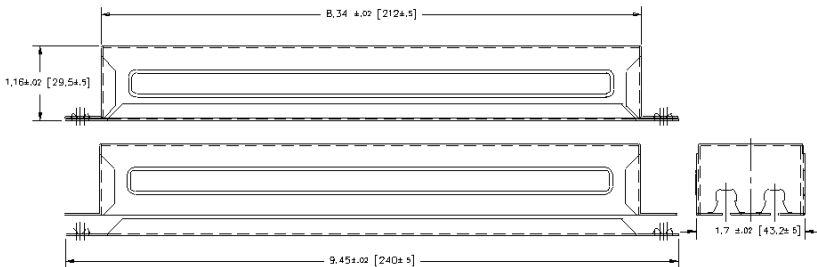

Fig. D

LED Drivers
Xtanium

Xtanium LED ELECTRONIC DRIVERS

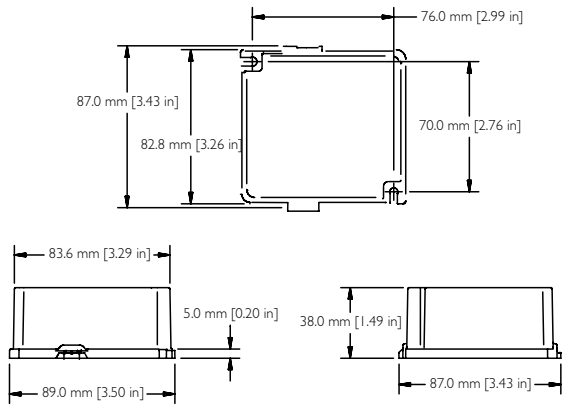

Fig. E

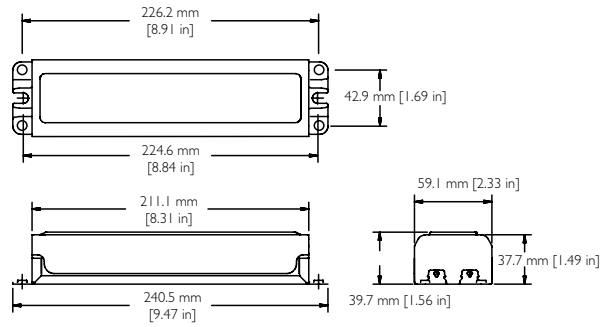

Fig. F

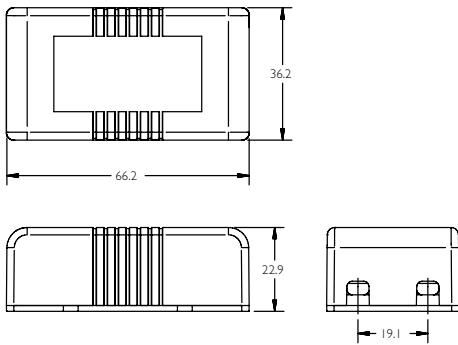

Fig. G

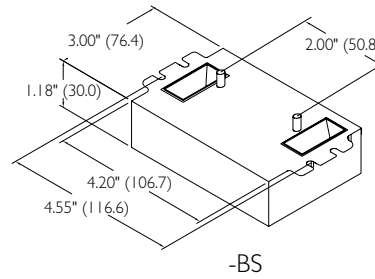

Fig. H

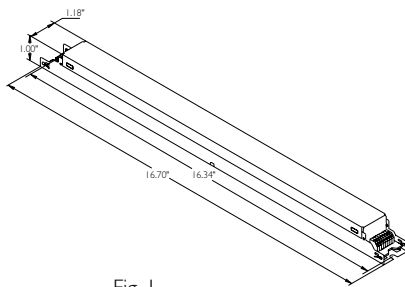
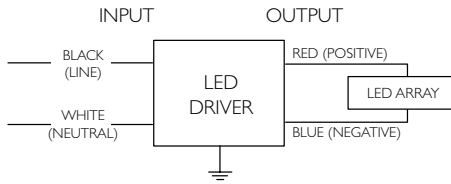

Fig. I

Includes connectors with no leads

Xtanium LED ELECTRONIC DRIVERS



Diag. 1

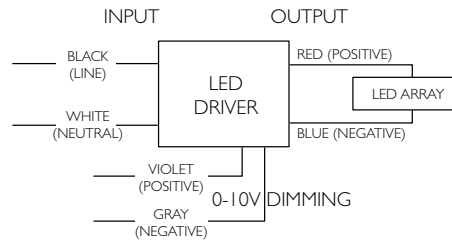

Diag. 2

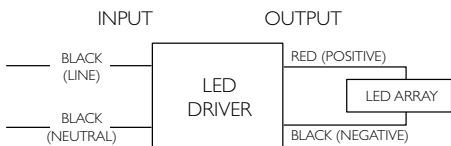

Diag. 3

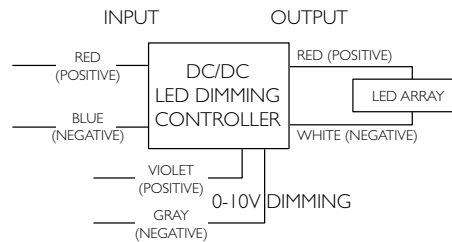

Diag. 4

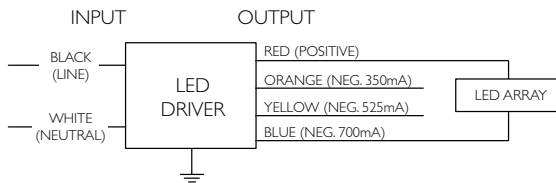

Diag. 5

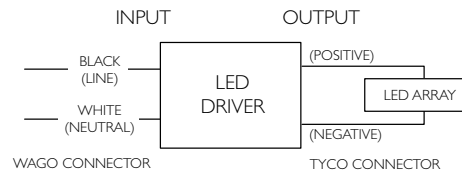

Diag. 6

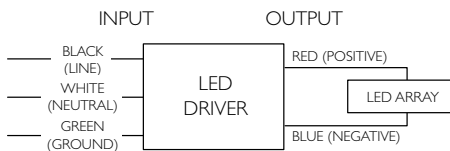

Diag. 7

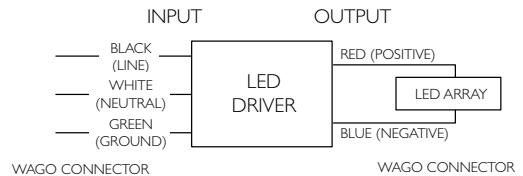

Diag. 8

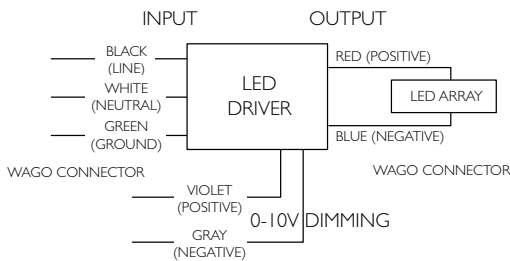

Diag. 9

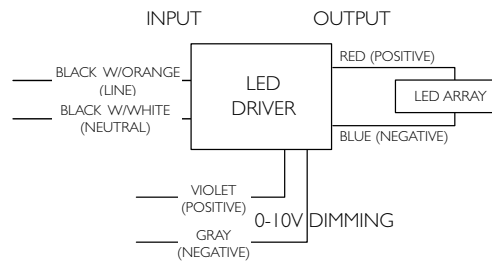

Diag. 10

Xtanium LED ELECTRONIC DRIVERS

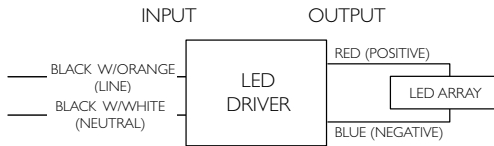

Diag. 11

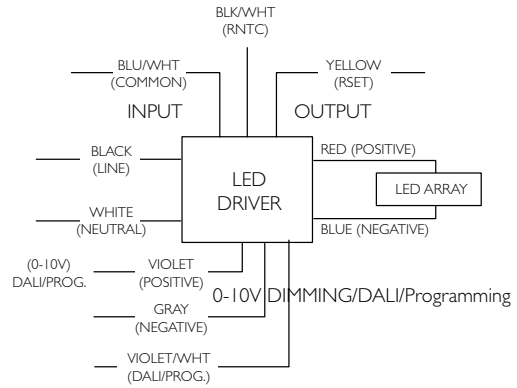

Diag. 12

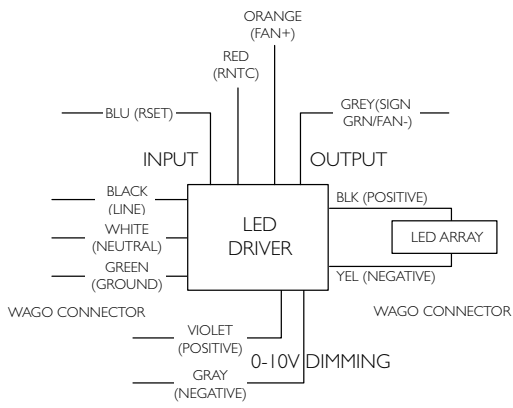

Diag. 13

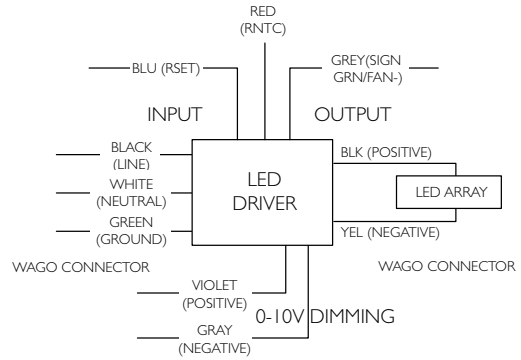

Diag. 14

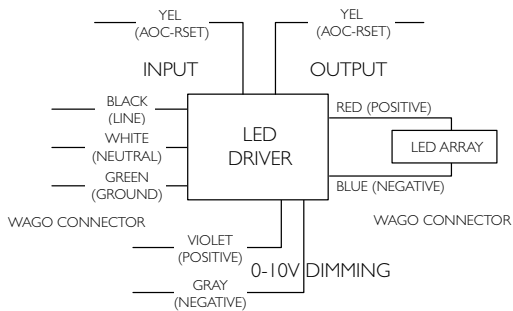

Diag. 15

LED Drivers
Xtanium