

## PRODUCT FEATURES

- ANSI Designation: M59 or H33
- Line Voltage: 120/208/240/277
- Regulation: 10%
- Frequency: 60 Hz
- Recommended Fuse (A): 10/8/5/5
- Circuit Type: CWA (Without Ignitor)
- Insulation Class: 180°C
- Capacitor Value: 24 MF
- Capacitor Voltage Rating: 400 V
- Capacitor Temperature Rating: 90°C
- Winding Materials: Cu/Al
- Lamp Starter: N/A
- Agency Certification: RU, cRU
- Maximum Distance to Lamp: N/A
- 2 Year Warranty

**LAMP TYPE:** 400W MH

**INPUT VOLTAGE:** Quad Tap (120/208/240/277)

**CIRCUIT TYPE:** CWA (Without Ignitor)

## ELECTRICAL SPECIFICATIONS

LINE VOLT (V)	POWER FACTOR	LINE CURRENT			INPUT POWER (W)	OPEN CIRCUIT VOLTAGE (V)	MINIMUM START TEMP	UL TEMP CODE	WIRING DIAGRAM
		OPERATING	OPEN	START					
120	High	3.95	4.09	3.30	443	318	-30°C	B	H2
208	High	2.27	2.47	2.07	443	318	-30°C	C	H2
240	High	1.95	2.11	2.11	443	318	-30°C	C	H2
277	High	1.72	1.84	1.43	443	318	-30°C	C	H2

## WIRING DIAGRAMS

DIAGRAM H2

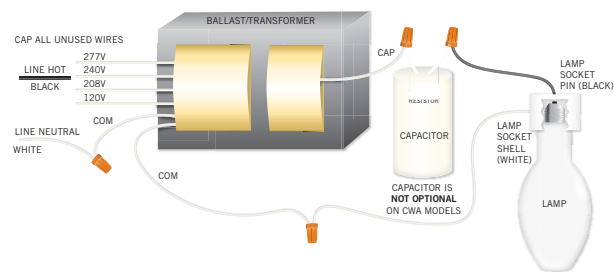
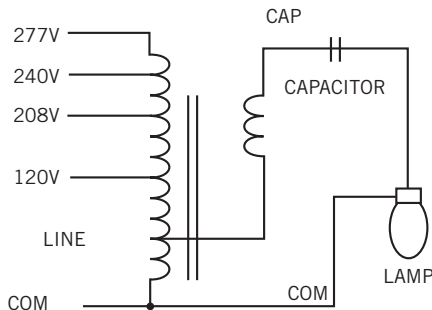

COLORS SHOWN REPRESENT THE MOST COMMON CONFIGURATION. HOWEVER, DEPENDING ON THE APPLICATION AND LOCAL CODE, SLIGHT DIFFERENCES MAY EXIST.

## CASE STYLE/DIMENSIONS

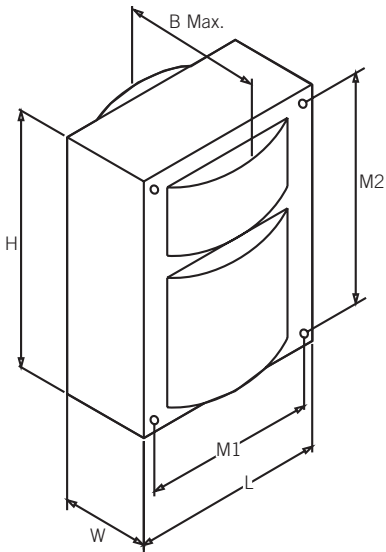

### OVERALL DIMENSIONS

LENGTH: 4.30"
WIDTH: 2.30"
HEIGHT: 4.80"
B MAX: 4.53"

### MOUNTING HOLES

DIAMETER: 0.25"
M1: 3.87"
M2: 4.38"

### BRACKET DIMENSIONS

LENGTH: 7.25"
WIDTH: 1.11"

**LEAD LENGTH:** 12-14"

**BALLAST NET WEIGHT:** 11.68 lbs

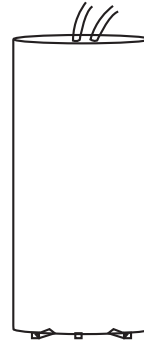

### CAPACITOR INFO

WATTAGE: 400
MICROFARAD: 24
VOLTAGE: 400V
TYPE: Dry Film

## ORDERING INFORMATION

ORDER CODE	PACKAGING STYLE	PACK QTY.	ITEM STATUS
MH-400A-Q-KIT		1	Quick Ship
*Kit Includes: Pre-Wired Ballast, Capacitor, Mounting Brackets, Mounting Hardware			

## CATALOG NUMBER BREAKDOWN

# MH-400A-Q-KIT

