



PRODUCT FEATURES

- Number of Lamps: 1
- Lamp Type: 2'-4', Bi-Pin, T5 and T5HO
- AC Input Current: 91mA @ 120V; 46mA @ 277V
- AC Input Power: 10W @ 120V; 11W @ 277V
- Battery Life: 1 Year

LIGHT OUTPUT: 700 Lumens	INPUT VOLTAGE: 120-277V	WARRANTY: 2 Years
ILLUMINATION TIME: 90 Minutes	INPUT FREQUENCY: 50/60 Hz	BATTERY: Ni-Cad

CASE STYLE/DIMENSIONS

CASE DIMENSIONS

LENGTH: 18.00"
WIDTH: 1.18"
HEIGHT: 1.18"

STANDARD LEAD LENGTHS*

YELLOW: 33.47"
BLUE/WHITE: 8.66"
BLUE: 6.69"
WHITE/BLACK: 7.87"
RED: 30.71"
RED/WHITE: 8.66"
BLACK: 37.40"
WHITE: 26.77"
WHITE/RED: 33.47"
WHITE/BLACK: 13.78"
RED: 33.47"

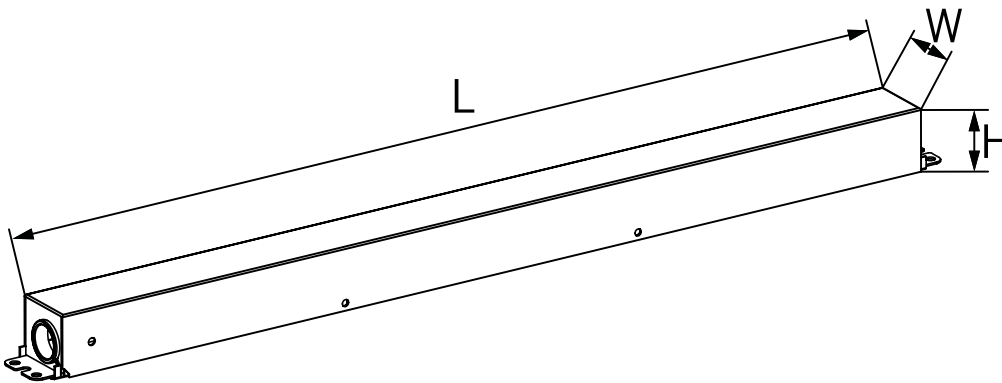

ORDERING INFORMATION

ORDER CODE	PACKAGING STYLE	PACK QTY.	ITEM STATUS
KT-EMRG-700-T5-IP	Individually Packed	1	Quick Ship

CATALOG NUMBER BREAKDOWN



WIRING DIAGRAMS

DIAGRAM 1-1 (One Lamp Instant Start Ballast)

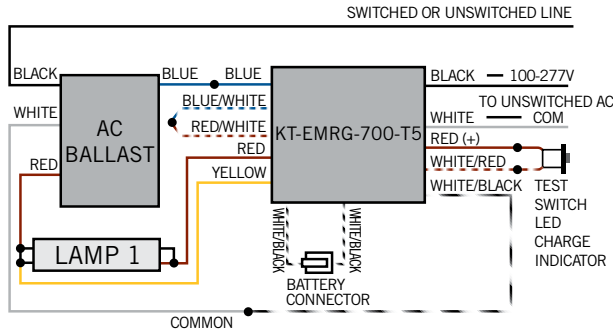

DIAGRAM 1-2 (One Lamp Rapid Start Ballast)

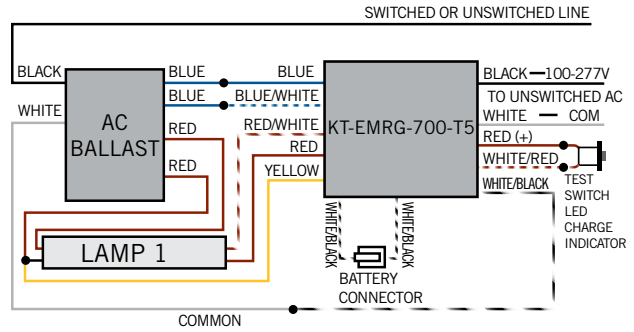

DIAGRAM 2-1 (Two Lamp Instant Start Ballast)

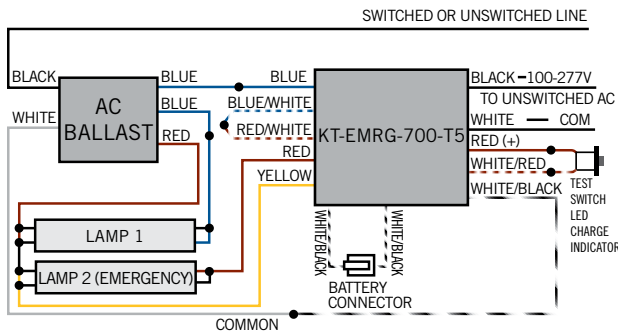

DIAGRAM 2-2 (Two Lamp Rapid Start Ballast)

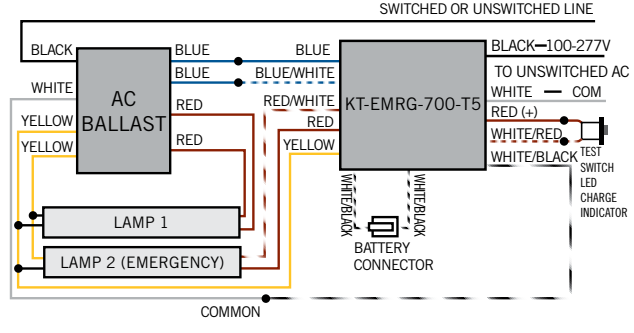

DIAGRAM 2-3 (Two Lamp Instant Start Ballast)

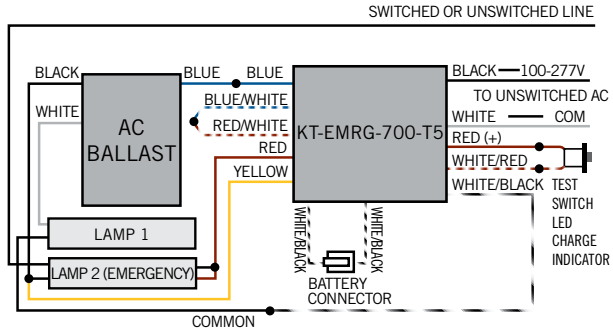

DIAGRAM 3-1 (Three Lamp Instant Start Ballast)

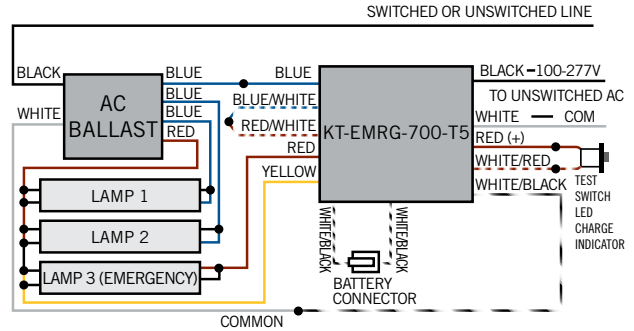

DIAGRAM 3-2 (Three Lamp Rapid Start Ballast)

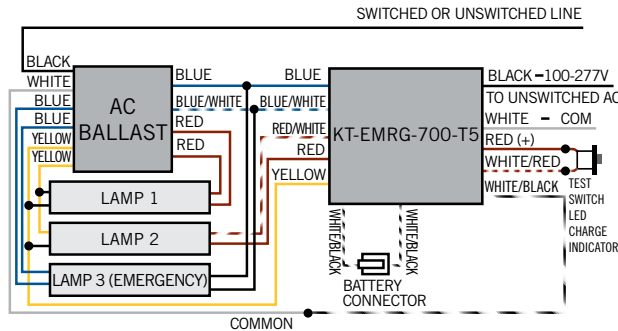

DIAGRAM 4-1 (Four Lamp Instant Start Ballast)

