

## PRODUCT FEATURES

- ANSI Designation: S50
- Line Voltage: 120/208/240/277
- Regulation: 5%
- Frequency: 60 Hz
- Recommended Fuse (A): 8/5/4/4
- Circuit Type: CWA
- Insulation Class: 180°C
- Capacitor Value: 35 MF
- Capacitor Voltage Rating: 280 V
- Capacitor Temperature Rating: 90°C
- Winding Materials: Cu/Cu
- Lamp Starter: XG-02
- Agency Certification: RU, cRU
- Maximum Distance to Lamp: 10 FT
- 2 Year Warranty

**LAMP TYPE:** 250W HPS

**INPUT VOLTAGE:** Quad (120/208/240/277)

**CIRCUIT TYPE:** CWA

## ELECTRICAL SPECIFICATIONS

LINE VOLT (V)	POWER FACTOR	LINE CURRENT			INPUT POWER (W)	OPEN CIRCUIT VOLTAGE (V)	MINIMUM START TEMP	UL TEMP CODE	WIRING DIAGRAM
		OPERATING	OPEN	START					
120	High	2.60	1.91	1.25	300	184	-40°C	B	H3
208	High	1.55	1.11	0.73	300	184	-40°C	B	H3
240	High	1.30	0.97	0.65	300	184	-40°C	B	H3
277	High	1.15	0.85	0.58	300	184	-40°C	B	H3

## WIRING DIAGRAMS

DIAGRAM H3

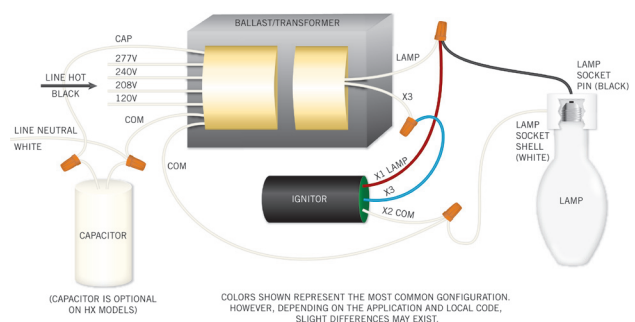
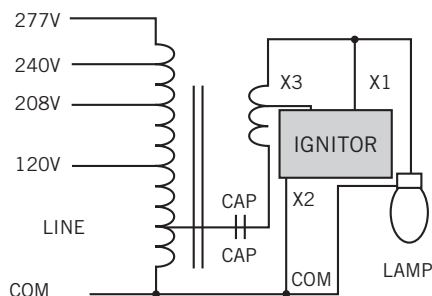

## CASE STYLE/DIMENSIONS

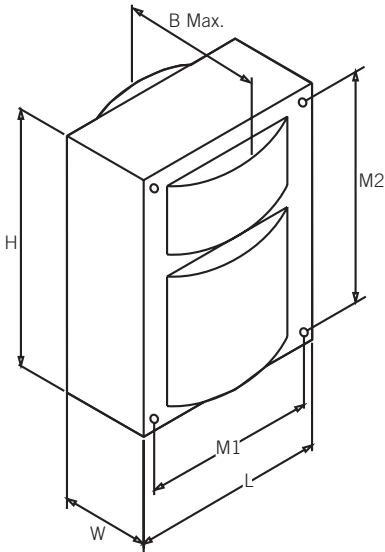

### OVERALL DIMENSIONS

LENGTH: 4.30"
WIDTH: 1.81"
HEIGHT: 4.80"
B MAX: 3.43"

### MOUNTING HOLES

DIAMETER: 0.25"
M1: 3.87"
M2: 4.38"

### BRACKET DIMENSIONS

LENGTH: 7.25"
WIDTH: 1.11"

**LEAD LENGTH:** 12-14"

**BALLAST NET WEIGHT:** 10.67 lbs

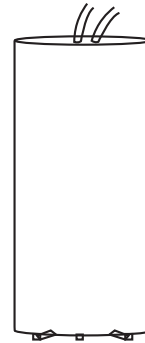

### CAPACITOR INFO

WATTAGE: 250
MICROFARAD: 35
VOLTAGE: 280
TYPE: Dry Film



### IGNITOR INFO

LAMP TYPE: High Pressure Sodium
WATTAGE: 250
TYPE: CWA

## ORDERING INFORMATION

ORDER CODE	PACKAGING STYLE	PACK QTY.	ITEM STATUS
HPS-250A-Q-KIT		1	Quick Ship
*Kit Includes: Pre-Wired Ballast, Capacitor, Ignitor, Mounting Brackets, Mounting Hardware			

## CATALOG NUMBER BREAKDOWN

# HPS-250A-Q-KIT

