

PRODUCT FEATURES

- ANSI Designation: S52
- Line Voltage: 120/208/240/277/480
- Regulation: 10%
- Frequency: 60 Hz
- Recommended Fuse (A): 20/15/10/10/8
- Circuit Type: CWA
- Insulation Class: 180°C
- Capacitor Value: 26 MF
- Capacitor Voltage Rating: 500 V
- Capacitor Temperature Rating: 90°C
- Winding Materials: Cu/Cu
- Lamp Starter: XG-03
- Agency Certification: RU, cRU
- Maximum Distance to Lamp: 15 FT
- 2 Year Warranty

LAMP TYPE: 1000W HPS

INPUT VOLTAGE: 5 Tap (120/208/240/277/480)

CIRCUIT TYPE: CWA

ELECTRICAL SPECIFICATIONS

LINE VOLT (V)	POWER FACTOR	LINE CURRENT			INPUT POWER (W)	OPEN CIRCUIT VOLTAGE (V)	MINIMUM START TEMP	UL TEMP CODE	WIRING DIAGRAM
		OPERATING	OPEN	START					
120	High	9.50	5.27	5.75	1080	443	-40°C	E	H9
208	High	5.30	3.11	3.40	1080	443	-40°C	E	H9
240	High	4.80	2.71	2.90	1080	443	-40°C	E	H9
277	High	4.30	2.35	2.60	1080	443	-40°C	E	H9
480	High	2.50	1.35	1.80	1080	443	-40°C	E	H9

WIRING DIAGRAMS

DIAGRAM H9

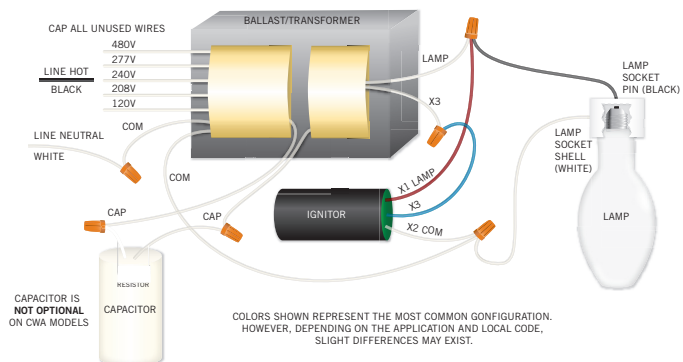
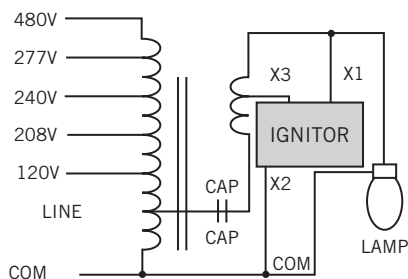

CASE STYLE/DIMENSIONS

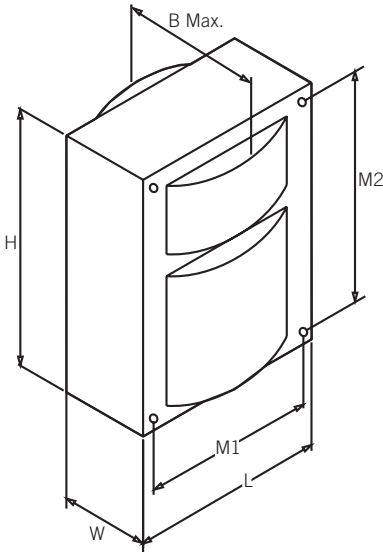

OVERALL DIMENSIONS

LENGTH: 4.30"
WIDTH: 3.76"
HEIGHT: 6.02"
B MAX: 6.18"

MOUNTING HOLES

DIAMETER: 0.25"
M1: 3.89"
M2: 5.37"

BRACKET DIMENSIONS

LENGTH: 7.25"
WIDTH: 1.11"

LEAD LENGTH: 12-14"

BALLAST NET WEIGHT: 27.22 lbs

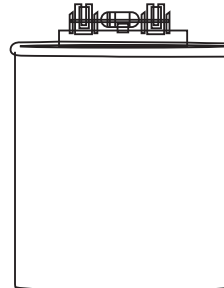

CAPACITOR INFO

WATTAGE: 1000
MICROFARAD: 26
VOLTAGE: 500V
TYPE: Oil Film



IGNITOR INFO

LAMP TYPE: High Pressure Sodium
WATTAGE: 1000
TYPE: CWA

ORDERING INFORMATION

ORDER CODE	PACKAGING STYLE	PACK QTY.	ITEM STATUS
HPS-1000A-P-HP-KIT		1	Quick Ship
*Kit Includes: Pre-Wired Ballast, Capacitor, Ignitor, Mounting Brackets, Mounting Hardware			

CATALOG NUMBER BREAKDOWN

HPS-1000A-P-HP-KIT

