

MPAL PRO 15 Watt Premium Multi-Purpose LED Area Luminaire



The MPAL PRO 15 Watt series is a group of premium architectural LED area luminaires designed to illuminate parking areas, pathways, building facades, loading docks, and a wide variety of other large, general site lighting applications. Multiple mounting options make the MPAL PRO 15 Watt a versatile luminaire for flood lighting, pole-, ground- and wall-mounted area lighting, and other outdoor lighting requirements.

MOUNTING

- Aluminum die-cast knuckle-mount option is installed on a junction box. Includes ½" NPS stem with locking nut.
- Yoke-mount option provides secure attachment to flat surfaces

WARRANTY/LISTING

- cULus listed for wet locations in ambient temperatures from -20°C to 45°C (-4°F to 113°F).
- IP66 rated for ingress protection.
- DLC premium approved.
- Rated for 3G vibration.
- Lens is IK 8 rated for protection from external impacts.
- Salt fog tested for 1,000 hours (ASTM B 117). After salt fog testing, paint rated at 9 per ASTM D 1654-05 scratch test.
- Complies with FCC Part 15, class B.
- Complies with EN61000-4-5, surge immunity protection (2.5kV).
- 5-year warranty of all electronics and housing.

FEATURES

- Available in 3000k (warm white), 4000k (neutral white) and 5000k (cool white) color temperatures.*
- Long-life LEDs provide 372,000 hours of operation with at least 70% of initial lumen output (L70).* *
- LEDMPALPRO 15 provides 1,593 lumens (114 lumens per watt, LPW) at 3000k; 1,603 lumens (115 LPW) at 4000k; and 1,624 lumens (116 LPW) at 5000k.*
- Standard optic provides an IES roadway type V distribution, or a 7V (vertical) x 7H (horizontal) NEMA floodlight distribution.
- Universal 120-277 AC voltage (50-60Hz) is standard.
- Power factor > 0.90.
- Total harmonic distortion < 20%.
- Color rendering index > 80.
- Optional glare shields (full & half) & wire guards are available.
- Die cast aluminum housing with durable, dark bronze powder coat finish—at least 2 mils thick on all surfaces—and a heat-resistant polycarbonate lens.
- Wireway enclosure is sealed with a water-tight, silicon rubber gasket.
- Effective projected areas (EPA's) are:
 - Front = 0.05 s.f. (knuckle) / 0.06 s.f. (yoke)
 - Side = 0.07 s.f. (knuckle & yoke)
 - Face = 0.20 s.f. (knuckle) / 0.23 s.f. (yoke)
- Easy installation in new construction or retrofit applications.

* Contact factory for other color temperatures and lumen packages.

**L₇₀ hours are IES TM-21-11 calculated hours.

MPAL PRO 15 Watt Premium Multi-Purpose LED Area Luminaire

DIMENSIONS

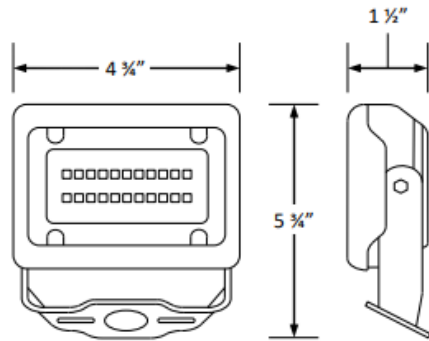

MPAL PRO 15 WATT ORDERING INFORMATION

Model	Mounting Options	Color Temperature
MPALPRO15	K = Knuckle Mount Y = Yoke Mount	3K = 3000K 4K = 4000K 5K = 5000K

Order Example:

MPALPRO15-Y-3K

SPECIFICATIONS

Model	Color Temp	CRI ¹	Luminaire Lumens	Watts	Lumens Per Watt	Input Voltage ²	Input Current (A)	Power Factor	THD ³	L ₇₀ Hours ⁴
MPALPRO15	3000K	> 80	1593	14	114	120-277	120V 240V 277V	> 90%	< 20%	372000
	4000K	> 80	1603	14	115	120-277	0.12 0.06 0.05	> 90%	< 20%	372000
	5000K	> 80	1624	14	116	120-277	0.12 0.06 0.05	> 90%	< 20%	372000

¹ Color rendering index.

² All 50-60Hz.

³ Total harmonic distortion.

⁴ L₇₀ refers to the number of hours at which lumen output declines to 70% of the initial level. L₇₀ hours are IES TM-21-11 calculated hours.

