

DIMENSIONS AND DATA

4 1/4 X 4 3/4 CORE - 2 COIL UNIT

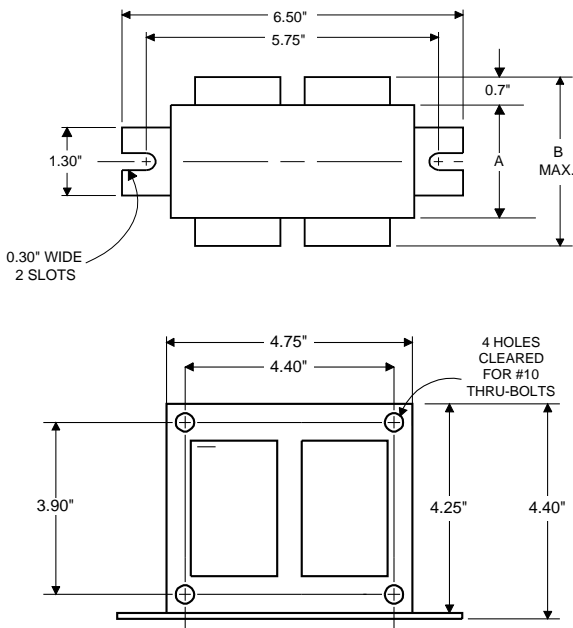

	120	208	240	277
INPUT VOLTS				
CIRCUIT TYPE	SUPER-CWA			
POWER FACTOR (min)	90%			
REGULATION				
Line Volts	±10%			
Lamp Watts	±10%			
LINE CURRENT (Amps)				
Operating.....	3.40	1.95	1.70	1.50
Open Circuit.....	2.30	1.40	1.20	1.11
Starting.....	3.05	1.75	1.50	1.32
UL TEMPERATURE RATINGS				
Insulation Class	H(180°C)			
Coil Temperature Code	1029			
MIN. AMBIENT STARTING TEMP.	-20°F or -30°C			
NOM. OPEN CIRCUIT VOLTAGE	280			
INPUT VOLTAGE AT LAMP DROPOUT.....	82	141	166	188
INPUT WATTS	374			
RECOMMENDED FUSE (Amps).....	10	7	7	5
CORE and COIL				
Dimension (A)	2.35			
Dimension (B)	4.20			
Weight (lbs.)	14			
Lead Lengths	12"			
CAPACITOR REQUIREMENT				
Microfarads	26.0			
Volts (min.)	330			
Fault Current Withstand (amps)				
60 Hz TEST PROCEDURES (Refer to Philips Lighting Electronics N.A. TEST Procedure for HID Ballasts - Form 127 High Potential Test (Volts)				
1 minute	2000			
2 seconds	2500			
Open Circuit Voltage Test (Volts)	255-315			
Short-Circuit Current Test (Amps)				
Secondary Current	3.30-4.90			
Input Current.....	2.45-3.65	1.40-2.10	1.20-1.80	1.05-1.60

Capacitor: 7C260P33-R



Capacitance: 26
Dia/Oval Dim: 1.75
Height: 4.8
Temp Rating: 105°C

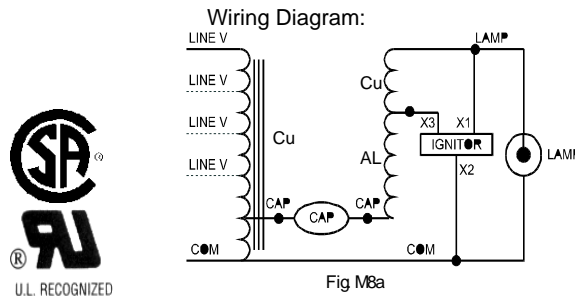

Typical Ordering Information

(please call Philips Lighting Electronics N.A. for suffix availability)

Order Suffix	Description
EE	EISA COMPLIANT - 88% EFFICIENT BALLAST

Ignitor: LI533-H4



Red (X1)
White (X2)
Blue (X3)

Ballast to Lamp Distance
(BTL) = 2 feet
Temp Rating: 105°C

Data is based upon tests performed by Philips Lighting Electronics N.A. in a controlled environment and is representative of relative performance. Actual performance can vary depending on operating conditions. Specifications are subject to change without notice.

PHILIPS LIGHTING ELECTRONICS N.A.

10275 WEST HIGGINS ROAD · ROSEMONT, IL 60018

Tel: 800-322-2086 · Fax: 888-423-1882 · www.philips.com/advance

Customer Support/Technical Service: 800-372-3331 · OEM Support: 866-915-5886