

**PHILIPS
ADVANCE**

**High Pressure
Sodium
Lamp Ballast**

**Catalog Number 71A7907
For 70W S62
60 Hz R-HPF
Status: Active**

DIMENSIONS AND DATA

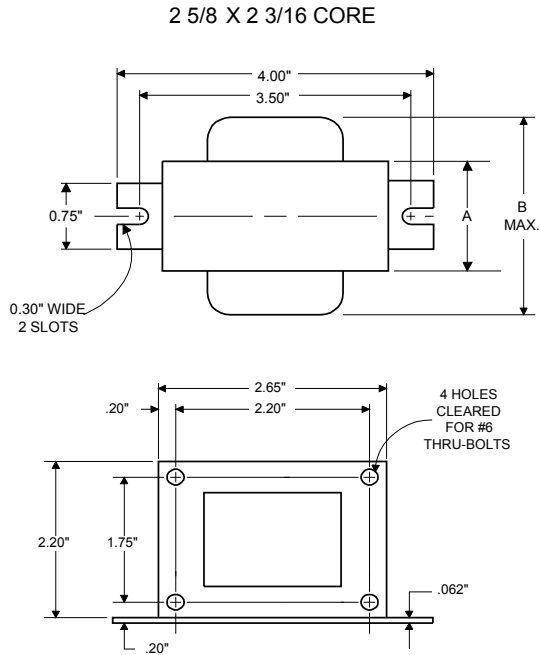

INPUT VOLTS	120				
CIRCUIT TYPE	R-HPF				
POWER FACTOR (min)	90%				
REGULATION					
Line Volts	±5%				
Lamp Watts	WITHIN TRAPEZOID				
LINE CURRENT (Amps)					
Operating.....	0.75				
Open Circuit.....	1.30				
Starting.....	0.90				
UL TEMPERATURE RATINGS					
Insulation Class	H(180°C)				
Coil Temperature Code	1029	A			
MIN. AMBIENT STARTING TEMP.	-40°F or -40°C				
NOM. OPEN CIRCUIT VOLTAGE	120				
INPUT VOLTAGE AT LAMP DROPOUT.....	96				
INPUT WATTS	86				
RECOMMENDED FUSE (Amps).....	3				
CORE and COIL					
Dimension (A)	1.30				
Dimension (B)	2.50				
Weight (lbs.)	2				
Lead Lengths	12"				
CAPACITOR REQUIREMENT					
Microfarads	28.0				
Volts (min.)	120				
Fault Current Withstand (amps)					
60 Hz TEST PROCEDURES (Refer to Philips Lighting Electronics N.A. TEST Procedure for HID Ballasts - Form 127 High Potential Test (Volts)					
1 minute	2000				
2 seconds	2500				
Open Circuit Voltage Test (Volts)	114-126				
Short-Circuit Current Test (Amps)					
Secondary Current	1.90-2.90				
Input Current.....	0.65-1.05				

Capacitor: 7C280M12



Capacitance: 28
Dia/Oval Dim: 1.5
Height: 2.9
Temp Rating: 105°C

Wiring Diagram:

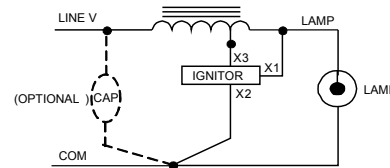

Fig. G

Typical Ordering Information

(please call Philips Lighting Electronics N.A. for suffix availability)

Order Suffix	Description

Ignitor: LI551-H4



Red (X1)
White (X2)
Blue (X3)

Ballast to Lamp Distance
(BTL) = 2 feet
Temp Rating: 105°C

Data is based upon tests performed by Philips Lighting Electronics N.A. in a controlled environment and is representative of relative performance. Actual performance can vary depending on operating conditions. Specifications are subject to change without notice.

PHILIPS LIGHTING ELECTRONICS N.A.

10275 WEST HIGGINS ROAD · ROSEMONT, IL 60018
Tel: 800-322-2086 · Fax: 888-423-1882 · www.philips.com/advance
Customer Support/Technical Service: 800-372-3331 · OEM Support: 866-915-5886

Revised: 05/16/03